

M1462/S

Eclipse

Eclipse Wall Lamp Switched 2 Light G9, Polished Chrome



LINE DRAWING

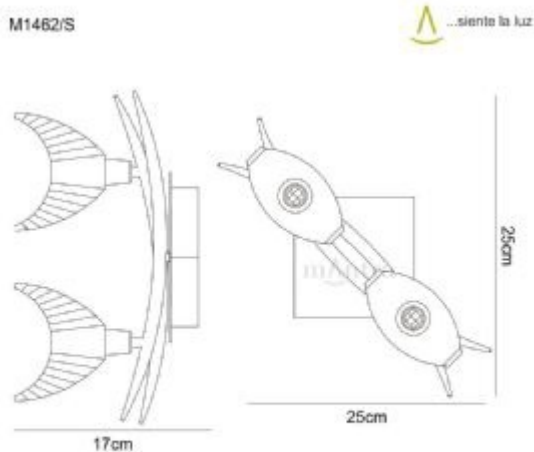

Eclipse Registered design

ENERGY LABEL

DATA SHEET

MARKETING INFORMATION

Barcode	5055498603092
Brief Description	Eclipse Crystal Switched Wall Lamp 2 Light
Catalogue Description	2 Light Switched Wall Light

PHYSICAL CHARACTERISTICS

Colour Finish	Polished Chrome
---------------	-----------------

MECHANICAL SPECIFICATION

Item Nett Weight (kg)	1.4kg
Width (mm)	250mm
Height (mm)	250mm
Projection (mm)	170mm
Materials Used	Iron, Crystal

ENERGY SPECIFICATION

Energy Class	A++ to D
--------------	----------

CRYSTAL SPECIFICATION

Type of Crystal	K9
Crystal Colour Finish	Clear

LAMP SPECIFICATION

No: of Lamp	2
Lamp Socket	G9
Recommended Lamp	LED/Halogen (Capsule)
Max Wattage Lamp (W)	33W
Lamp Included	No

ELECTRICAL & SAFETY SPECIFICATION

Protection Class	Class 1 - Earth Connection Required
Total Power Consumption (W)	Dependent On Lamps Used
Input Voltage (V)	220-240V~50/60Hz
Switched	Yes - Rocker Switch
Dimmable	Yes - Dimmable Lamps Required
Dimmer Included	No
IP Rating	IP20

QUALITY STANDARDS

Inspired Lighting Ltd. are continually developing and improving their products.
Technical specifications subject to change without prior notice.

M1462/S

Eclipse



Warranty (yrs) 1yr

PRODUCT COMPONENT SPECIFICATION

Shade Colour Clear

CARTON INFORMATION

Number of Cartons 1

Carton Gross Weight (kg) 1.7kg

[Click to view the full product details](#)

OVERVIEW

Eclipse consists of twists, curves and strokes of metal work that converge to a point. The selective combination gives each item its own identity. The optical glass design is inspired by the nature of the moon and is enhanced with further cuts to create a special reflection. Eclipse is available in polished chrome and black chrome and both are as stunning as each other.

Inspired Lighting Ltd. are continually developing and improving their products.
Technical specifications subject to change without prior notice.