

# ENDON®

## Chesham Outdoor Wall light Fitting INSTRUCTION MANUAL

### Safety Warnings

- This product is only suitable for connection to a 240V~50Hz supply in accordance with current IEE wiring regulations. It should be installed in accordance with local building regulations and is for domestic use only.
- Before commencing installation of your light fitting always switch off the mains supply and remove the appropriate fuse or switch off the appropriate circuit breaker.
- This is a Class I product, and **must** be Earthed. The terminal blocks are supplied according to requirements of the fitting.
- Run supply wire from a 5-amp electrical supply protected by an RCD using double insulated 3-core cable of type H05RN-F 1.0mm<sup>2</sup> (not supplied) to selected site, ensuring it is adequately protected through the full length of the cable run, it must come out of the flat surface of the wall or steps in line with the entry to the fitting.
- Except where installed in a conduit or duct which provides equivalent protection against mechanical damage, a cable buried in the ground shall incorporate an earthed armour or metal sheath or both, suitable for use as a protective conductor, or be of insulated concentric construction. Buried cables shall be marked by cable covers or a suitable marking tape. Buried conduits and ducts shall be suitably identified. Buried cables, conduits and ducts shall be at a sufficient depth to avoid being damaged by any reasonably foreseeable disturbance of the ground.
- Never fit bulbs of a higher wattage than those specified on the label, as these may cause overheating and damage the fitting.
- This product has special protection against the ingress of water, and is rated IP44. If the glass or diffuser is damaged it must be replaced, please consult your retailer. This is the symbol which denotes this requirement:
- If you are in any doubt about your competence please consult a qualified electrician.
- If any modification is made it will invalidate the warranty and may render the product unsafe.

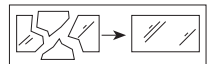

### Care Information

Allow 10 minutes to cool before replacing, adjusting or cleaning.

Clean with a dry cloth only. Do not use liquid or abrasive cleaners on this product.

### Assembly/ User Instructions

#### Before you start

Please read these instructions carefully before fitting and retain for reference. Check the packaging and make sure that you have all the required parts. Follow each assembly step in order to prevent incorrect assembly.

Ensure that the product is fully assembled as illustrated before use.

This light fitting is suitable for use with a dimmer switch, but may not be dimmed if using certain energy saving lightbulbs - please check lightbulb packaging.

#### The Light pack contains:

Light fitting.

Terminal connection block(s).

Fixing pack.

#### The following tools may be required:

Selection of cross and flat head screwdrivers.

Electric drill and assorted drill bits.

Wire strippers.

Electrical insulation tape.

**These assembly diagrams are intended as a guide – if in doubt consult a qualified electrician.**

1. Decide on the position of the light fitting, or remove existing light fitting. Note the position of the electrical connections. Ensure there is a solid mounting surface, preferably a wooden joist or joist bridge to support the weight of the light fitting.



## Assembly/ User Instructions Continued

2. Unscrew the glass shade (8), and fit the bulb (7). **NOTE: Never fit bulbs of a higher wattage than those specified on the label as these may cause overheating and damage the fitting.** Refit the shade, ensuring the seal is tight.
3. Remove the back box (2) by undoing the finials (6) from the threaded bolts.
4. Use the back plate as a template and mark the holes, making sure the back box is correctly aligned so that the threaded bolts are horizontal.
5. Bring the mains cable through the rubber grommet, then use appropriate fixings (1&4) to secure the back box to the wall.
6. Connect the house wiring to the internal terminal block (5) – see expanded wiring details below. **NOTE: This is a Class I fitting and must be earthed.** The cable entry grommet must be securely in place to ensure that the water ingress protection is maintained. When you are sure of the connections wrap the Terminal Block and overlap the wiring both sides with 2 layers of insulation tape.
7. Fit the front frame over the 2 threaded bolts in the back plate and secure with the finials (4). Take care not to trap or strain the internal cables, and ensure the rubber gasket (3) is correctly in place.
8. Turn on the power and test.

The PIR sensor settings (9) can be altered by turning the dials under the fitting marked 'SENS' and 'TIME'.

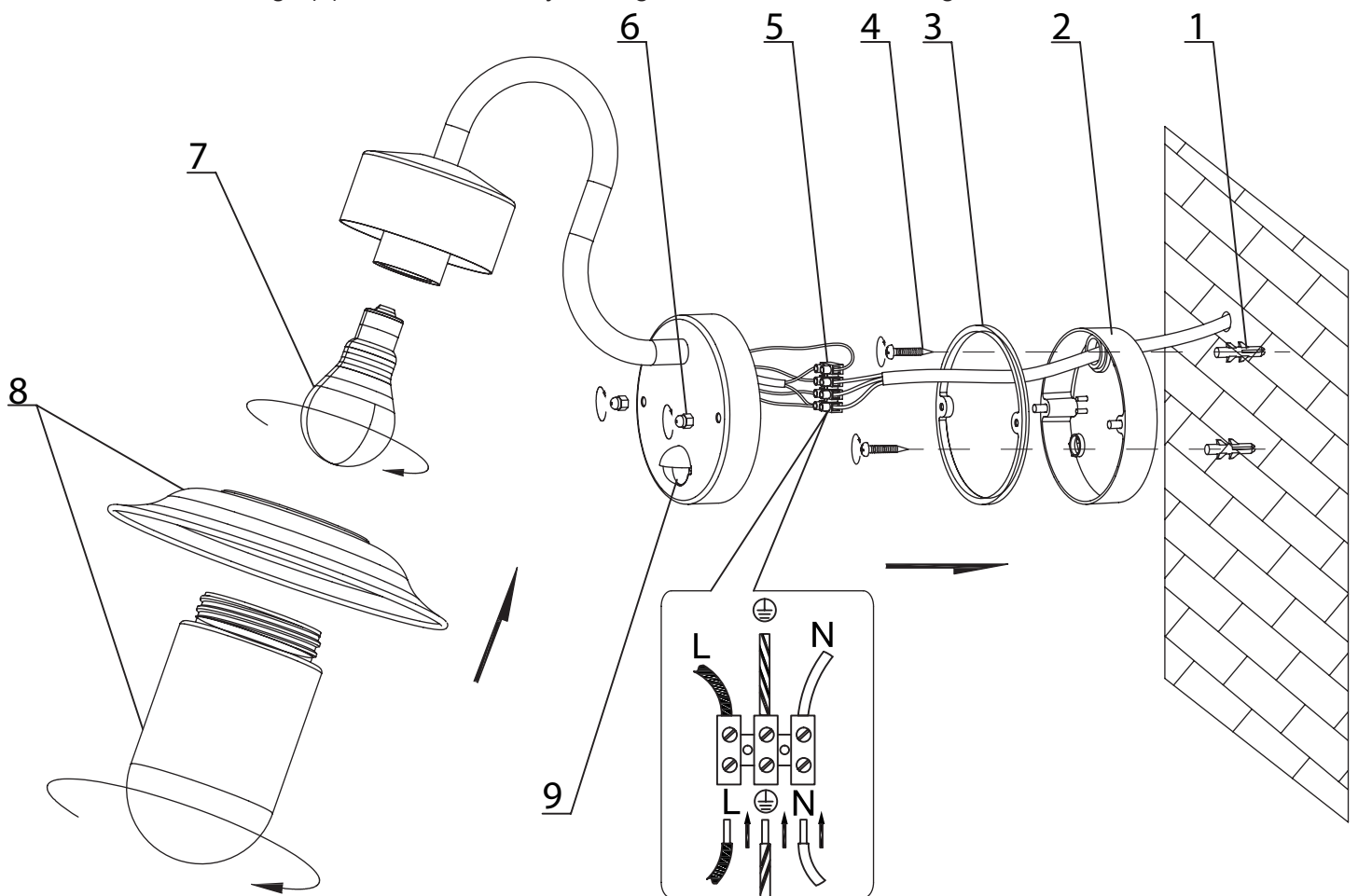

# Adjusting the PIR Sensor

- The unit must be installed in a vertical position, and fitted 1.8-2.5m above the ground.
- The PIR sensor can be adjusted, allowing the detection distance to be altered to suit the location. The LUX control level is adjustable between 10-20000 lux. The detection angle is set at 120 degrees. The duration that the lamp stays on can be altered from (10±5) seconds - (5±1) minutes. The detection distance "SENS" can be adjusted up to 8m. A small screwdriver is required to adjust the controls. When adjusting in daylight it will be necessary to cover the sensor to simulate night time.
- To access the adjustment screws flip down the cover over the PIR sensor. Take great care when adjusting the sensor screws not to overtighten as they can be easily broken.

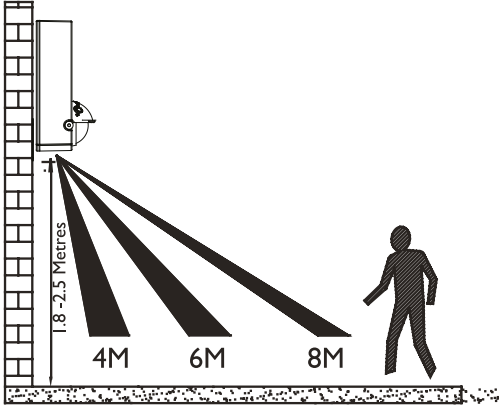
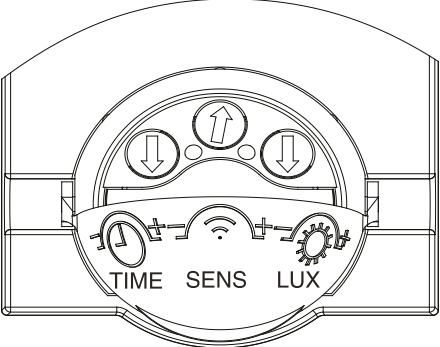
Adjustable up to 8 metres	PIR Adjustment
	
Detection range can be adjusted by turning 'SENS' screw	Duration the bulb stays on is adjustable by turning 'TIME' screw. The sensor trigger point is adjustable by turning the 'LUX' screw.